

MODEL 550 EQUALIZER

Features:

- Three range - eleven frequency boost or attenuation in steps to 12dB
- Shelving or peaking curves independently selectable for upper and lower ranges.
- Switchable audio band-pass filter
- Transformer coupled output to +28dBm
- Low noise and distortion
- Panel mounting 1½" x 5½"
- Utilizes Automated Processes' 2520 Op Amps

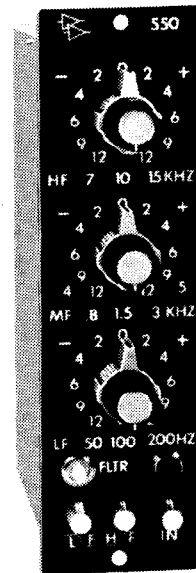

The Automated Processes Model 550 Equalizer is designed as a highly versatile channel module with reciprocal equalization at eleven frequency points in five steps of boost or attenuation to a maximum of 12dB at each point.

The eleven frequency points are divided into three ranges with the upper and lower ranges individually selectable as either peaking or shelving. This combination of possibilities makes the 550 ideally suited for all types of music or voice enhancement and effects equalization. A band-pass filter (50Hz to 15kHz) may be inserted independent of all other selected equalization settings.

Ten controls are provided to accomplish the various functions. Three dual concentric rotary switches perform frequency selection and degree of equalization for the three ranges; the inner knob selects the desired frequency while the outer knob sets the degree of boost or cut from a mid position (reciprocal equalization) in steps of 2, 4, 6, 9 and 12dB.

Two push buttons select either the bell-shaped peaking curves or shelving curves for the upper and lower frequency ranges. The five center frequencies in the mid-range are reciprocal bell-shaped peaking families.

A small toggle switch is used to insert the band-pass filter into the equalizer.

A push-button throws the equalizer networks in or out of the circuit while lighting a small tally light showing when equalization is "In". The switching is silent permitting use of this function during program.

In order to optimize signal to noise ratio over the widest possible range of operating conditions, two input/output connections are provided. The "High Level" connection is recommended for input levels between 0dBm and +12dBm and provides output capability to +28dBm. The "Low Level" connection permits operation at levels between -15dBm and 0dBm without encountering the usual increase in relative noise level. The maximum output capability in this connection is equivalently reduced to +20dBm.

The Model 550 Equalizer makes use of Automated Processes 2520 operational amplifiers and therefore exhibits the reliability, long life and uniformity which are characteristic of this device.

The Model 550 operates from a bipolar power supply of from ±15 to ±18 volts permitting latitude in system design and assurance of stability under normal operating conditions. It is reverse polarity protected and will withstand 150% transients reducing the likelihood of damage from power line surges and power supply malfunctions. Power decoupling is also provided to minimize signal coupling in the power supply lines.

5DB/OCT.

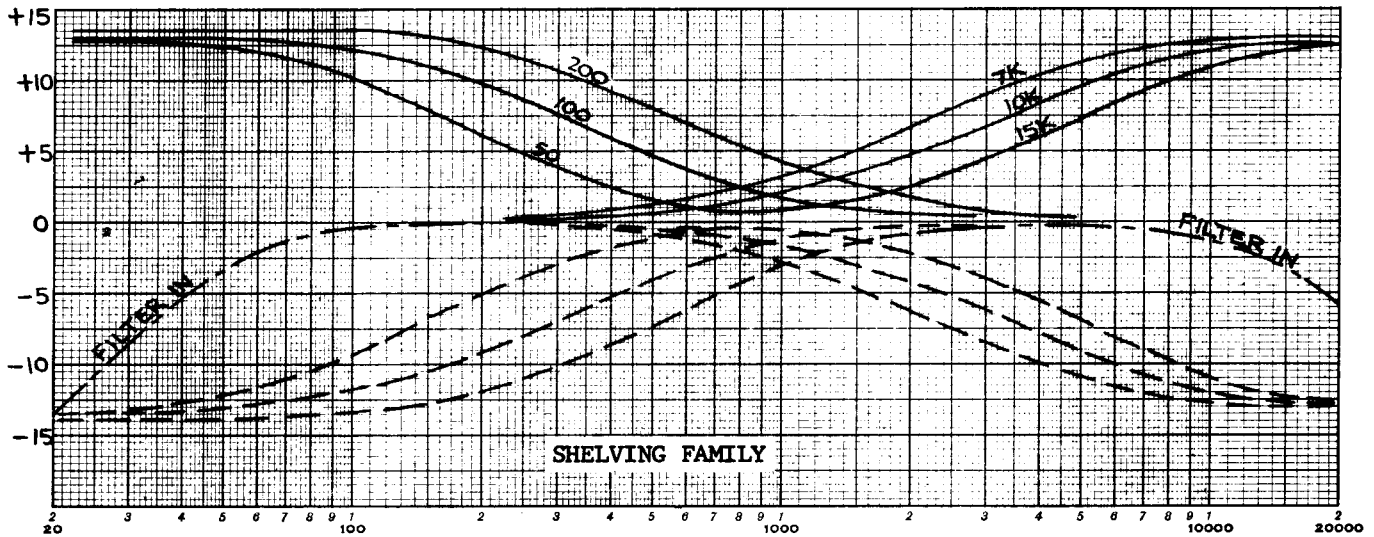
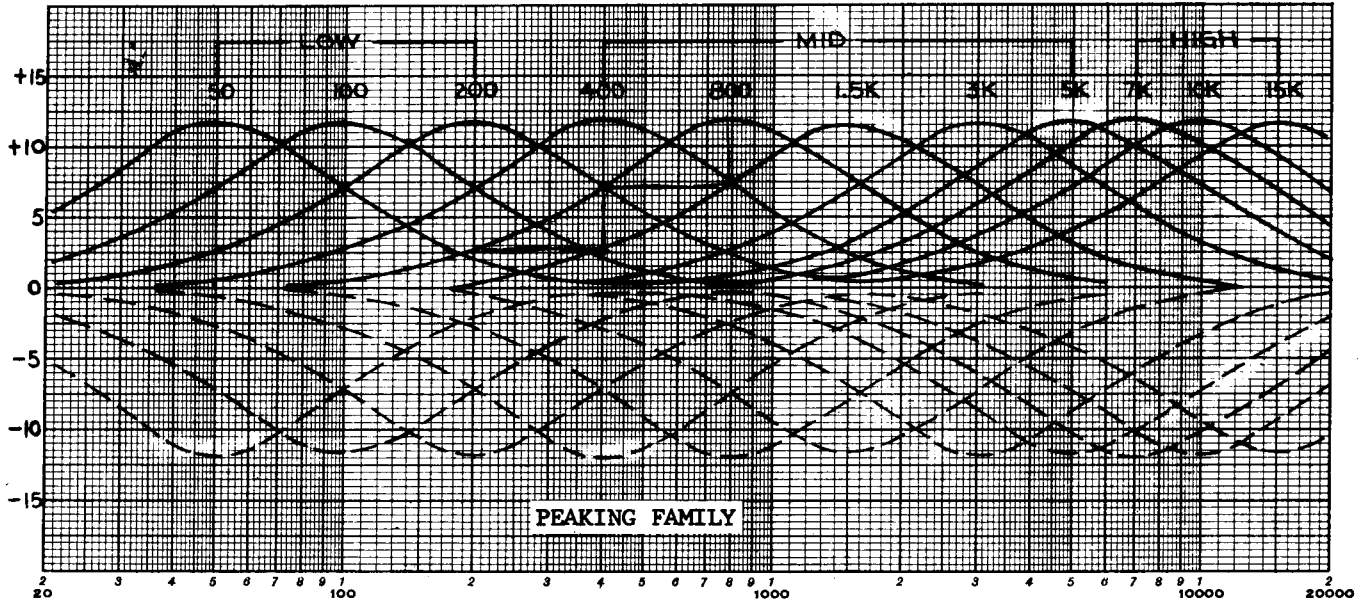

MODEL 550 EQUALIZER SPECIFICATIONS:

Input Impedance: 15k Ω high level, 6k Ω low level

Output Impedance: Less than 85 Ω

Nominal Operating Program Level: -15dBm to +12dBm

Insertion Loss: None (bridging)

Frequency Response, Unequalized: ± 0.5 dB 30Hz to 20kHz

Maximum Output Level: +28dBm, transformer isolated

Noise: Unequalized, equivalent to an input signal of -85dBm, high level strapping and -93dBm, low level strapping, 20Hz to 20kHz unweighted

Distortion: Less than 0.35% T.H.D. 30Hz to 20kHz at +28dBm output

Power Requirement: ± 15 volts @ 70mA, (12 volt, 30mA lamp on separate terminals. May be strapped to same power through dropping resistor furnished.)

Controls:

Dual Concentric Rotary: LF select: 50, 100, 200 Hz and stepped degree of equalization -12dB to +12dB

Dual Concentric Rotary: MF select: 400, 800, 1500, 3000, 5000 Hz and stepped degree of equalization -12dB to +12dB

Dual Concentric Rotary: HF select: 7000, 10,000, 15,000 Hz and stepped degree of equalization -12dB to +12dB

All equalization is in steps of 2, 4, 6, 9 and 12 dB either plus or minus

Toggle Switch: 50Hz to 15kHz band-pass filter In or Out

Push Button: LF range Peak or Shelf

Push Button: HF range Peak or Shelf

Push Button: Equalization In or Out.

Tally light when In

Dimensions: Escutcheon 1 $\frac{1}{2}$ x 5 $\frac{1}{2}$; case 5 3/4 behind panel

Connector: 30 pin PC connector supplied.

MODEL 550A EQUALIZER INSTALLATION

In order to optimize signal to noise ratio over the widest possible range of operating conditions, two input/output connections are provided. The "High Level" connection is recommended for input levels between 0dBm and +12dBm and provides output capability to +28dBm. The "Low Level" connection permits operation at levels between -15dBm and 0dBm without encountering the usual increase in relative noise level. The maximum output capability in this connection is equivalently reduced to +20dBm.

The Model 550A may be mounted in a suitably machined panel. A cutout of 4 11/16" by 1 15/32", and two #4-40 tapped holes will be required (see dimensional drawing). The panel of the Model 550A will overlap the panel cutout and holes. Connections are made to the 30 contact female connector supplied and are shown below.

<u>Terminal</u>	<u>Function</u>
1	Chassis Ground
2	Output High (High Level Signal)
3	Output High (Low Level Signal)
4	Output Low
5	Shield Ground (Power Common)*
6	Spare
7	Spare
8	Input Low (Power Common)*
9	Input High (Low Level Signal)
10	Input High (High Level Signal)
11	Gain Trim (See Note 2)
12	+15V Power Supply Input 60mA max.
13	±Power Supply Common*
14	-15V Power Supply Input 60mA max.
15	Spare

* These terminals are internally connected.

Tally Lamp

The Light Emitting Diode (LED) tally lamp draws 4 milliamps from the -15V supply.

Interchangeability with Model 550

The Model 550A is directly interchangeable with the earlier Model 550 on a pin for pin basis with the exception that pins 6 and 7 (Model 550 Tally Lamp Supply) need not be connected in order to operate the Model 550A LED Tally Lamp.

Gain Adjustment

The Model 550A is factory adjusted to provide unity voltage gain in both High Level and Low Level configurations. However, gain may be increased by the use of a gain trim resistor between terminals 8 and 11. The value of this resistor for various gain settings is given in the table below. An additional gain increase or reduction of approximately 8dB may be obtained by means of the input and output terminals provided. Connecting to High Level In and Low Level Out reduces gain, while Low Level In and High Level Out increases gain.

Gain in dB	Resistor Ω
0	Open
2	510
4	180
6	91
8	39
10	10
11	Short

RECOMMENDED
PANEL CUTOUT

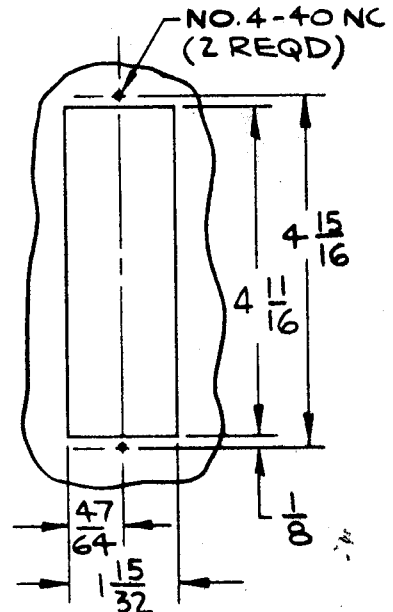

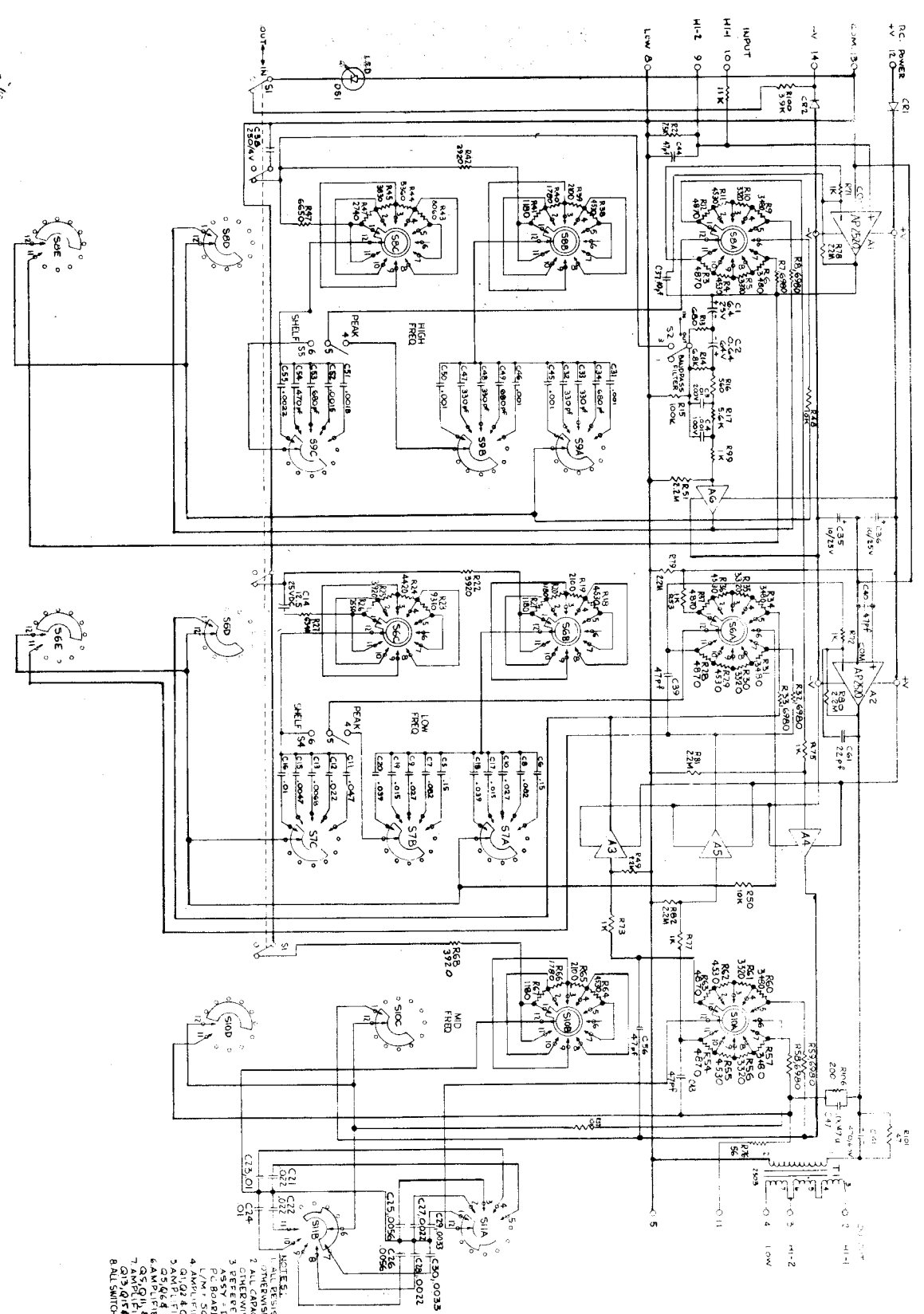

- NOTES:
1. ALL RESISTOR VALUES ARE IN OHMS UNLESS OTHERWISE SPECIFIED.
 2. OTHERWISE SPECIFIED.
 3. REFERENCE DWG 5.
 4. AMPLIFIER CIRCUIT A4 CONTAINS COMPONENTS Q1, Q2, Q4 AND R15 THRU R17, R102 AND C37.
 5. AMPLIFIER CIRCUIT A5 CONTAINS COMPONENTS Q3, Q5, Q7, Q8 AND R18 THRU R20, R103 AND C38.
 6. AMPLIFIER CIRCUIT A5 CONTAINS COMPONENTS Q5, Q7, Q8 AND R18 THRU R20, R103 AND C38.
 7. AMPLIFIER CIRCUIT A6 CONTAINS COMPONENTS Q9, Q10, Q11, Q12, Q13, Q14, Q15, Q16, Q17, Q18, Q19, Q20, Q21, Q22, Q23, Q24, Q25, Q26, Q27, Q28, Q29, Q30, Q31, Q32, Q33, Q34, Q35, Q36, Q37, Q38, Q39, Q40, Q41, Q42, Q43, Q44, Q45, Q46, Q47, Q48, Q49, Q50, Q51, Q52, Q53, Q54, Q55, Q56, Q57, Q58, Q59, Q60, Q61, Q62, Q63, Q64, Q65, Q66, Q67, Q68, Q69, Q70, Q71, Q72, Q73, Q74, Q75, Q76, Q77, Q78, Q79, Q80, Q81, Q82, Q83, Q84, Q85, Q86, Q87, Q88, Q89, Q90, Q91, Q92, Q93, Q94, Q95, Q96, Q97, Q98, Q99, Q100.
 8. ALL SWITCHES IN MAXIMUM CW POSITION.

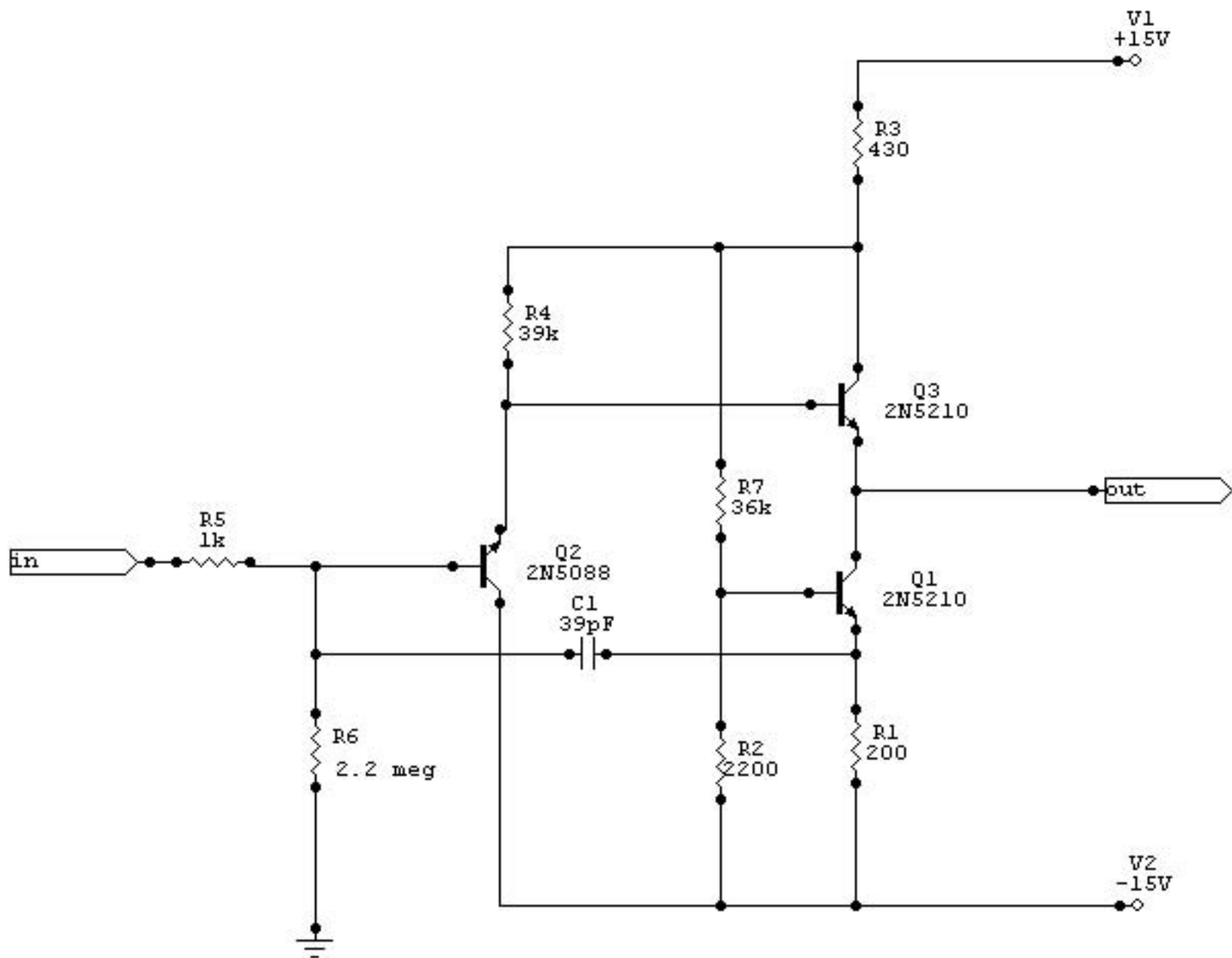

API 550A Buffer Amp
 A3, A4, A5, A6 on schematic